

**Electrical
technical
drawings**

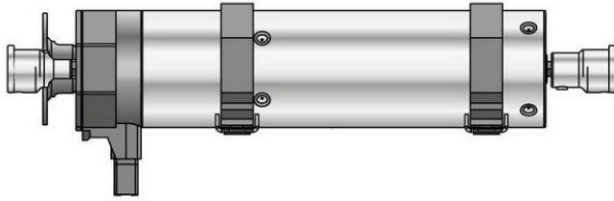

EV80 – Electrical Requirements



Remote Control Operation:

When Remote Control Technology is utilised, the blinds can be parallel wired. Each unit requires a three core 240 V (active, neutral and earth) feed which must then be connected to the supplied Evaya (Hirschmann) proprietary plug and tail. This cable plugs directly into the motor of the blind when installed.

Connecting Evaya Tail With TPS

ACTIVE – BROWN
 NEUTRAL – BLUE
 EARTH – GREEN
 BLACK – NOT REQUIRED IN REMOTE CONTROL

RS 485

By using an RS485 transmitter the installation can be configured to operate within a building automation system.

Wind Sensor

The Eolis sensor is designed to protect the EV80 systems against high wind damage. The remote control technology requires 240v power supply only as communication with shading systems occurs wirelessly. See mounting options.

Switch Control Operation

Power to the blinds **MUST NOT BE WIRED IN PARALLEL**. Irreparable damage to the motor and or installation will occur. Each blind requires it's own dedicated four core 240 V (2 x active, neutral and earth) feed which must then be connected to the supplied Evaya (Hirschmann) proprietary plug and tail. This cable plugs directly into the motor of the blind when installed.

Connecting Evaya Tail With TPS

ACTIVE – BROWN AND BLACK
 NEUTRAL – BLUE
 EARTH – GREEN

Wind Sensor

The Eolis WT (Wired Technology) unit is a sensor designed for building management system integration. The WT sensor is a wired sensor connected to a control unit within a central switch board hub. Wiring diagrams available on request. See mounting options

Current

As an indication, the motors draw 0.4 – 0.6 Amps under maximum load and therefore do not require their own circuit.

Location Of Power

As a guide the power should be located centrally across the width of the unit. Section images below highlight the feed based on the pelmet options.

Motor Location In Drive Assembly

- * Motor located in centre of the drive rail assembly
- * Power cable is always located on the RHS when viewed from outside of building looking in
- * Cable length from motor is 900mm

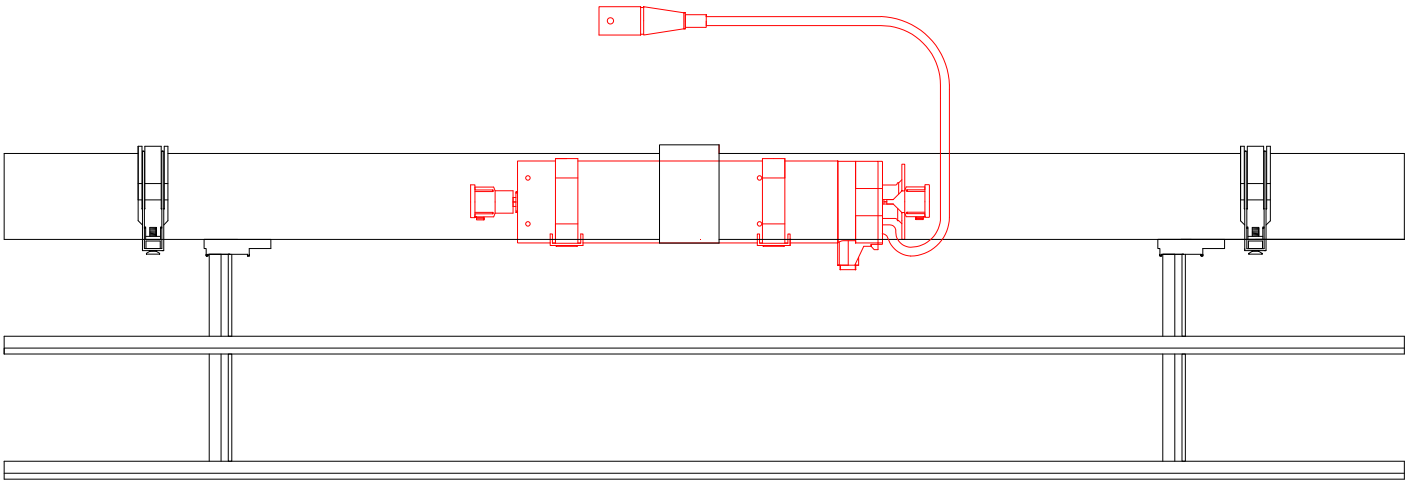

Evaya Pelmet Type A & B

- A - Indicates Power
- B - Indicates Hirschmann Plug Connection
- C - Indicates Motor

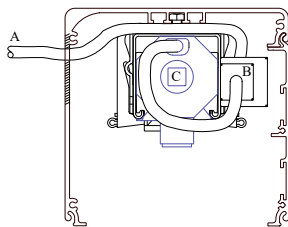

Face Entry

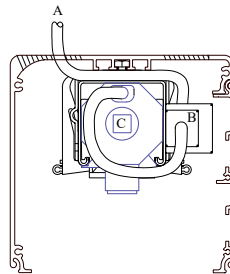

Top Entry 1

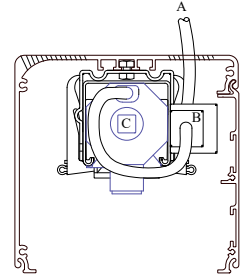

Top Entry 2

Evaya Pelmet Type C - Mounting Plate

- A - Indicates Power
- B - Indicates Hirschmann Plug Connection
- C - Indicates Motor

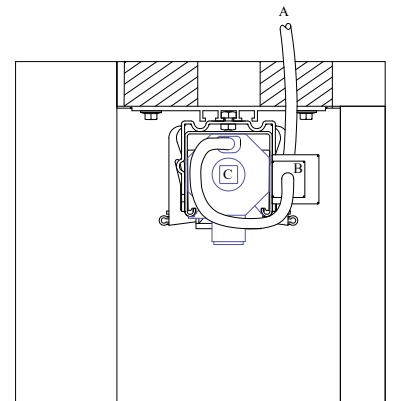
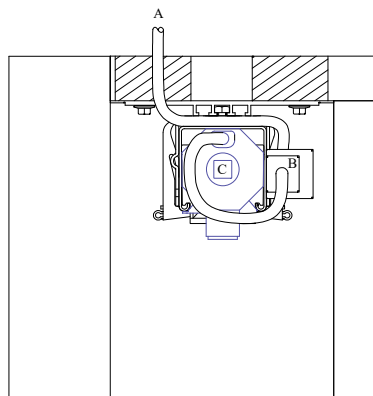
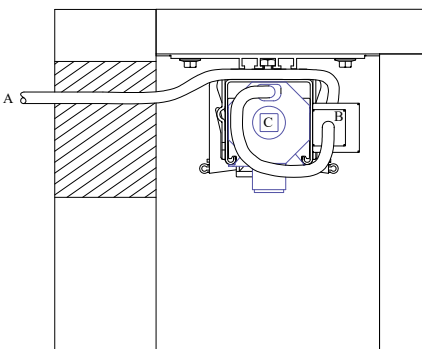

Wind Sensor – Operation & Mouting

The wind threshold can be adjusted by the potentiometer to accommodate varying wind speeds. When the wind speed exceeds the threshold set an up order is given to the shading systems. As long as the measured wind speed remains higher than the adjusted threshold, any commands to lower, raise or tilt the shading systems are inhibited. When the wind speed falls below the threshold setting, an order or command can be given. When specified, provision for the installation and correct wiring of an Eolis sensor must be provided for. Mounting options are as below. A wind sensor shroud, recommended for roof installations

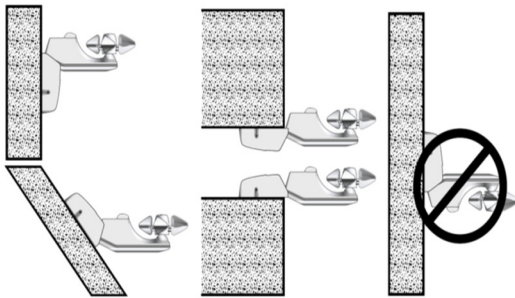
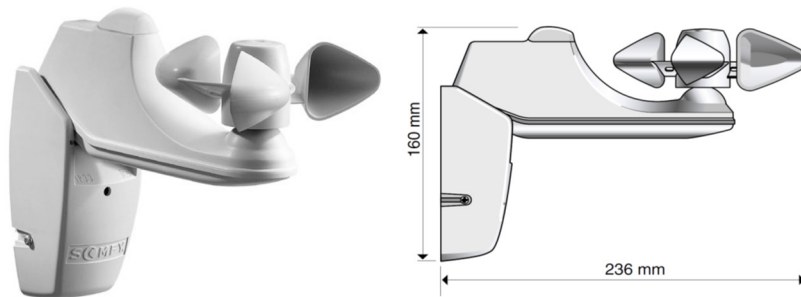

Eolis RTS - Product Data

- * The wind threshold can be adjusted to accommodate a wind speed within a minimum of 10 kmh to a maximum of 50 kmh.
- * Power Supply - 240v
- * Phase and Neutral
- * Two terminal screws inside sensor. No polarity.

Eolis With Soliris IB Building Automation - Product Data

- * The wind threshold can be adjusted to accommodate a wind speed within a minimum of 5 kmh to a maximum of 80 kmh.
- * Power Supply to Soliris IB - 240v
- * Wiring from Soliris IB to Eolis Sensor - 0.75mm pair. No voltage carried.
- * Two terminal screws inside sensor

4.2 Pelmet Type A & B - Pelmet Power Connection Options

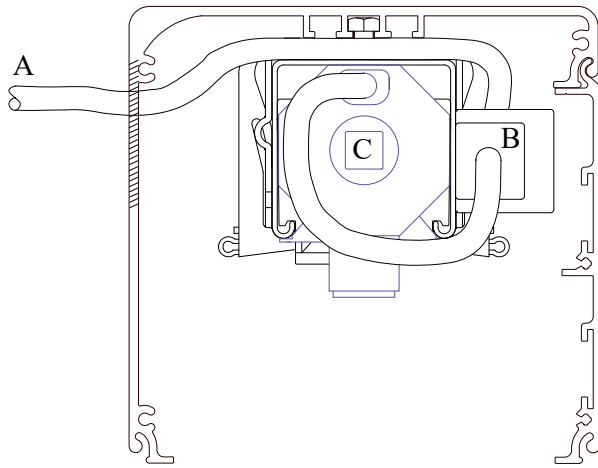

Face Entry

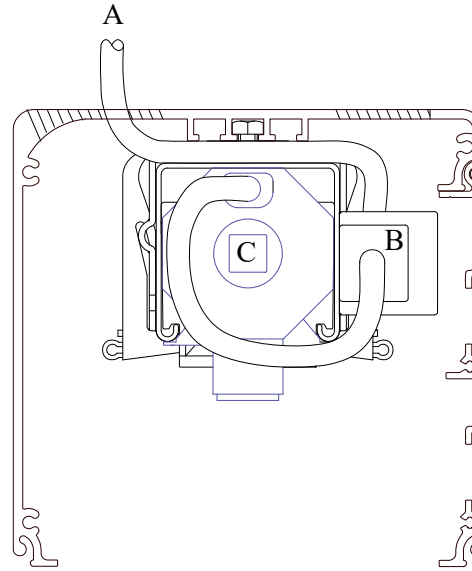

Top Entry 1

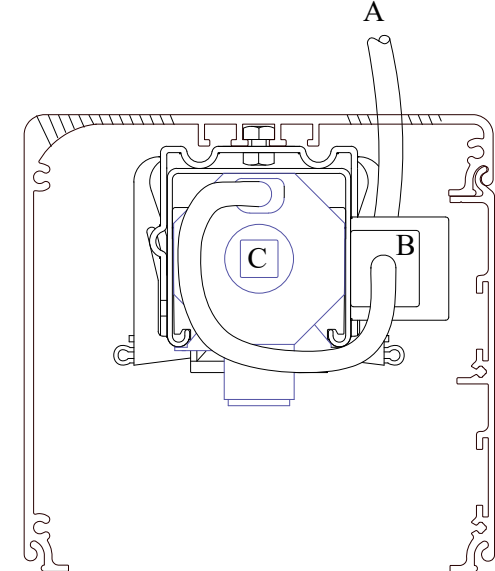

Top Entry 2

Shaded areas indicate usual entry for power to blind for both Face and Top

Note - 32mm min dia hole required for plug ends.

A - Power from dwelling to receiver / plug fitting

B - Receiver / plug fitting

C - Motor

4.3 Pelmet Type C Mounting Plate - Pelmet Power Connection Options

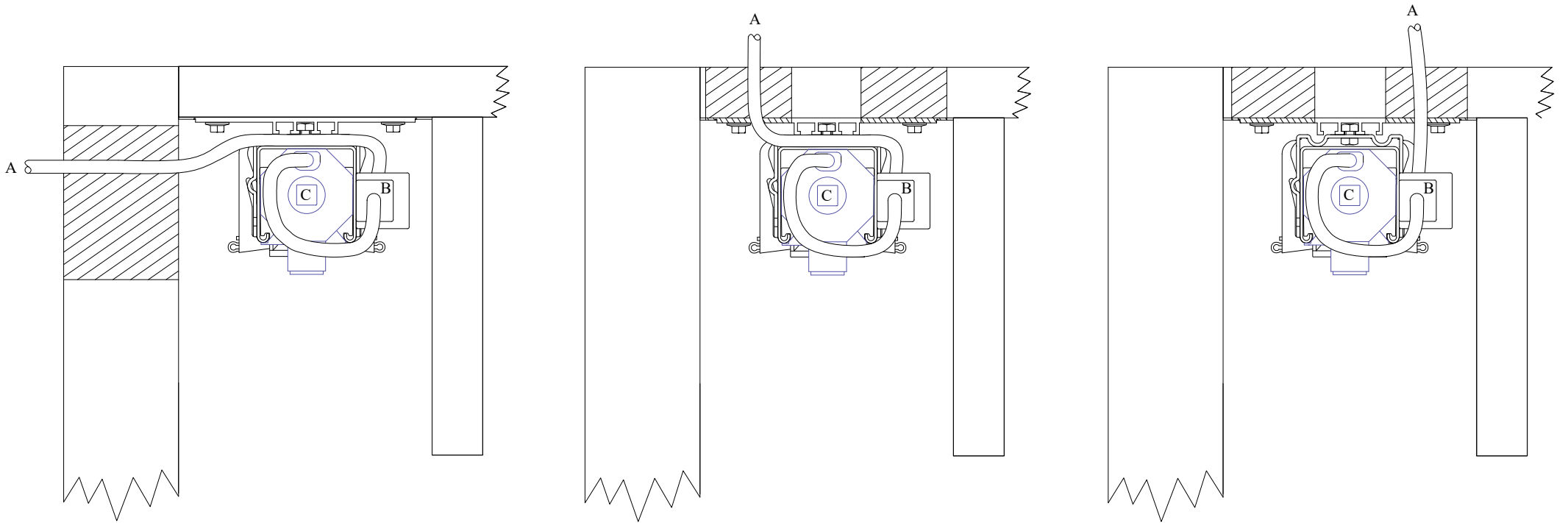

A - Power from dwelling to receiver / plug fitting
B - Receiver / plug fitting
C - Motor

Shaded areas indicate usual entry for power to blind
Note - 32mm min dia hole required for plug ends.



4.6 REMOTE RECEIVER - WIRING

MAINS POWER IN
ACTIVE
NEUTRAL
EARTH

MOULDED
PLUG

WIRELES RTS
RECEIVER

MOULDED
PLUG

4 CORE / TWIN ACTIVE
CABLE LENGTH - 1500MM
USE ONLY BROWN ACTIVE

4 CORE / TWIN ACTIVE MOTOR CABLE
CABLE LENGTH - 900MM

MOTOR

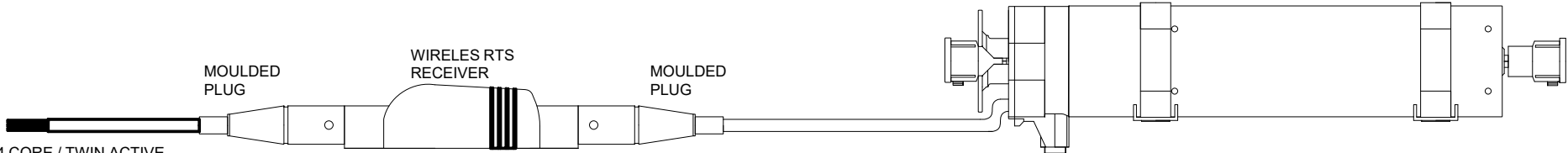

4.6a REMOTE RECEIVER - PATCH LEAD WIRING

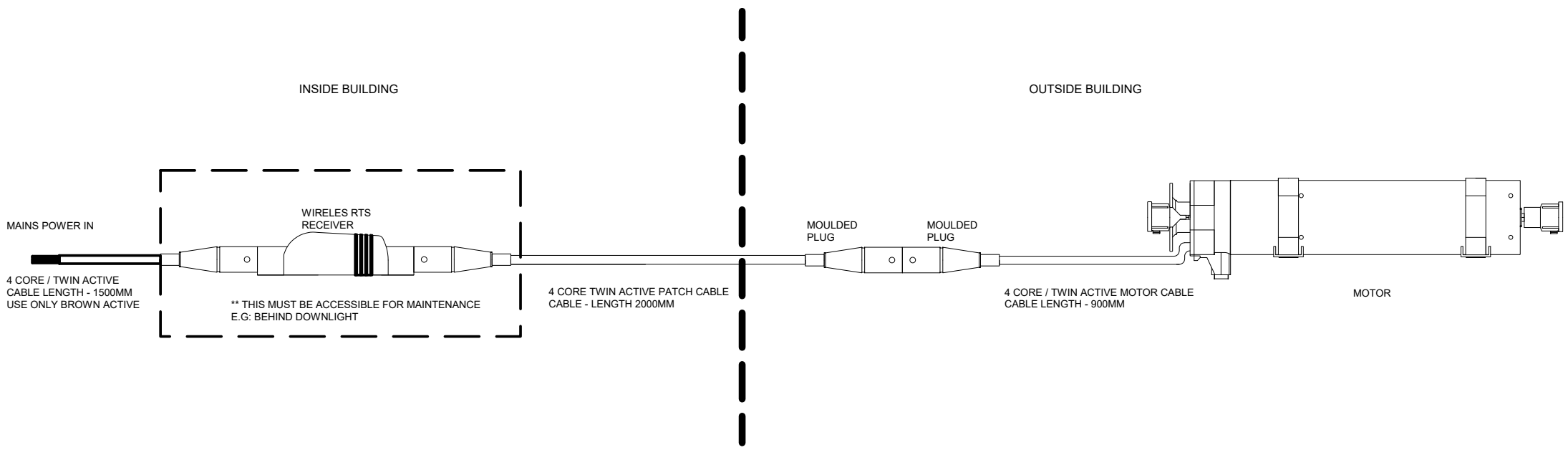

This wiring setup is ideal should the units be remote controlled and off ground level. It allows easy access to the Somfy inline receiver should maintenance be required. i.e power and the unit via the receiver is run back into the building.



4.6b REMOTE RECEIVER & WIND SENSOR - WIRING

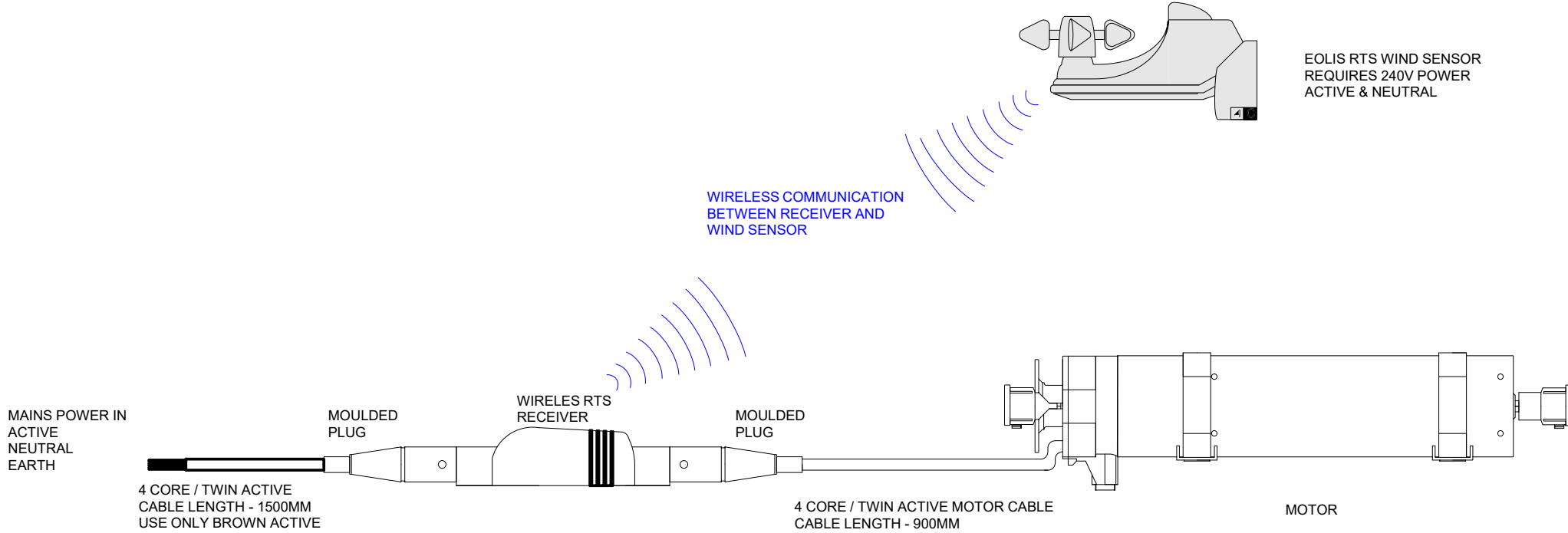

4.6c RS485 TRANSMITTER - WIRING

HOME AUTOMATION

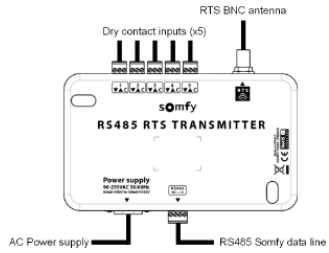

RS485 TRANSMITTER
COMMUNICATES
WIRELESSLY WITH
RTS RECEIVER

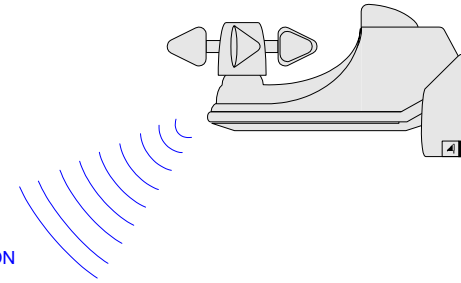

EOLIS RTS WIND SENSOR
REQUIRES 240V POWER
ACTIVE & NEUTRAL

WIRELESS COMMUNICATION
BETWEEN RECEIVER AND
WIND SENSOR

MAINS POWER IN
ACTIVE
NEUTRAL
EARTH

4 CORE / TWIN ACTIVE
CABLE LENGTH - 1500MM
USE ONLY BROWN ACTIVE

MOULDED
PLUG

WIRELES RTS
RECEIVER

MOULDED
PLUG

4 CORE / TWIN ACTIVE MOTOR CABLE
CABLE LENGTH - 900MM

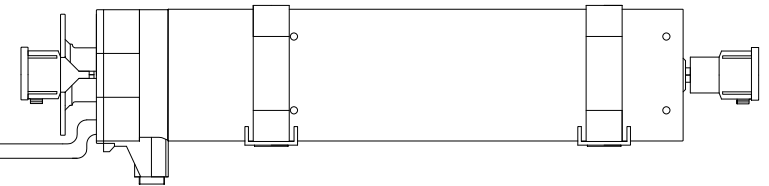

MOTOR

4.7 WIRING HIRSCHMANN CONNECTORS - CUSTOM LENGTH PATCH LEAD

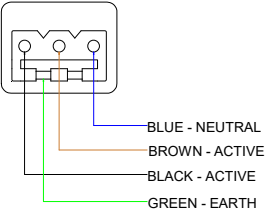
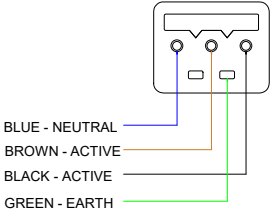
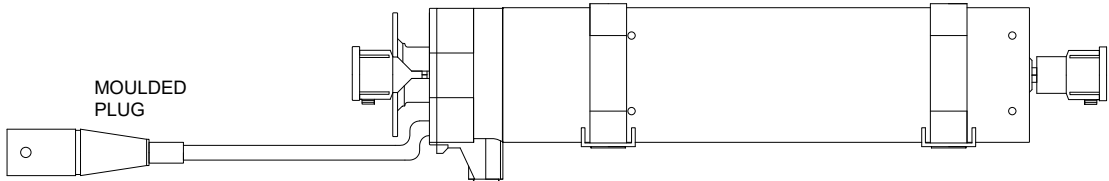
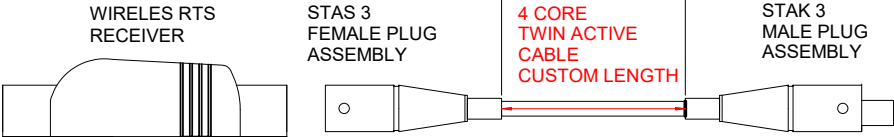

4.9 BMS 4AC Motor Controller To Motor and Wind Sensor

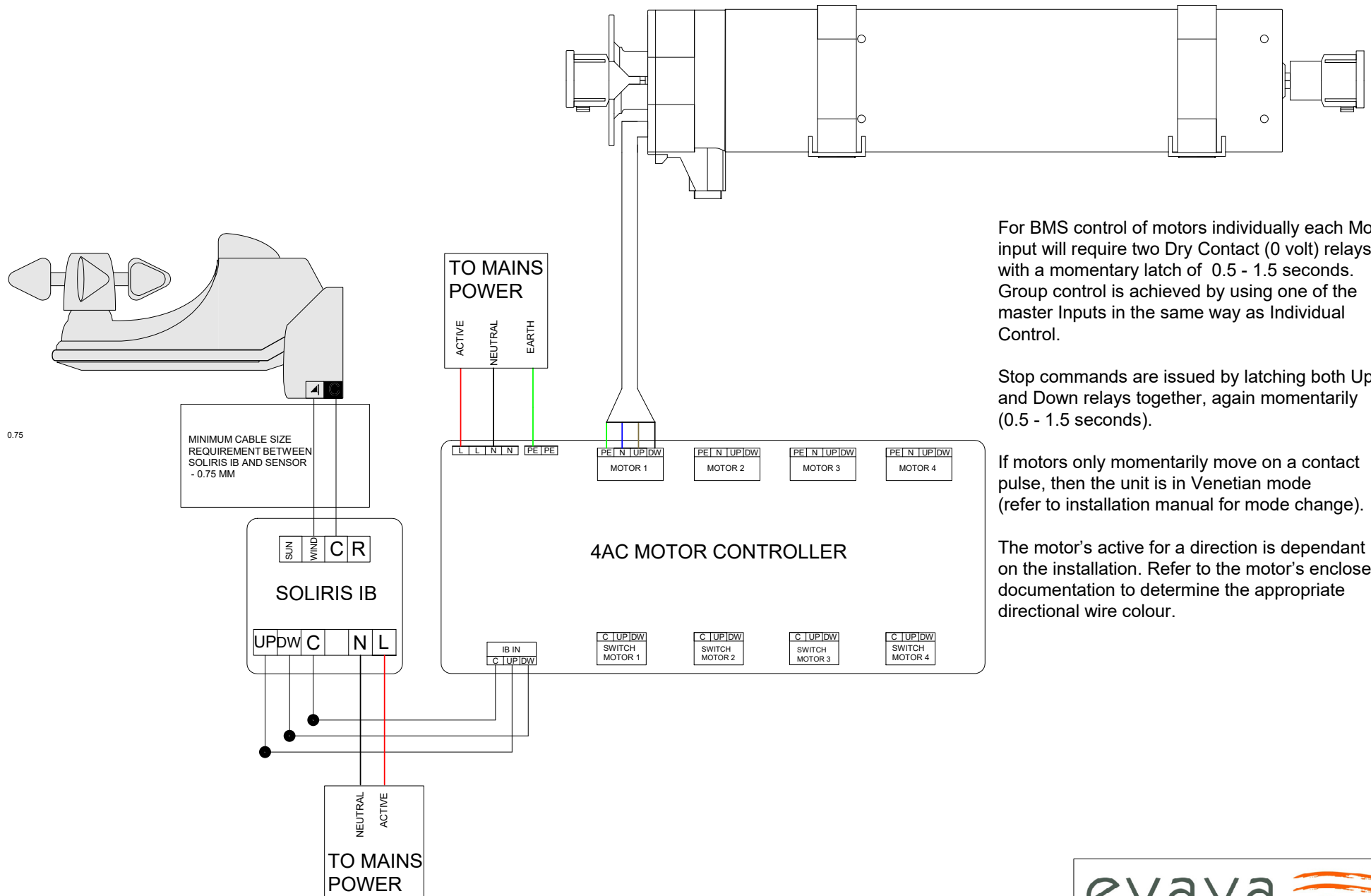

For BMS control of motors individually each Motor input will require two Dry Contact (0 volt) relays with a momentary latch of 0.5 - 1.5 seconds. Group control is achieved by using one of the master Inputs in the same way as Individual Control.

Stop commands are issued by latching both Up and Down relays together, again momentarily (0.5 - 1.5 seconds).

If motors only momentarily move on a contact pulse, then the unit is in Venetian mode (refer to installation manual for mode change).

The motor's active for a direction is dependant on the installation. Refer to the motor's enclosed documentation to determine the appropriate directional wire colour.

4.9a BMS DCT2 Remote Wired Motor Paired To Automation

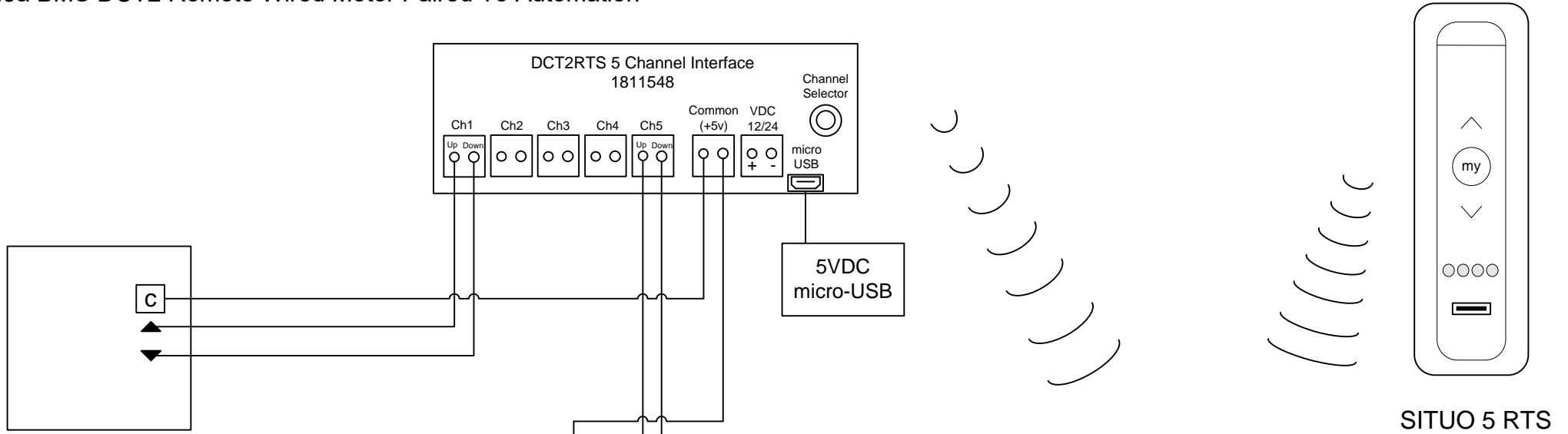

Note:

For BMS control of motors individually each channel input will require two Dry Contact (0 volt) relays with a momentary latch of 0.5 – 1 second.

Please refer to User Manual for Switch Compatibility table.

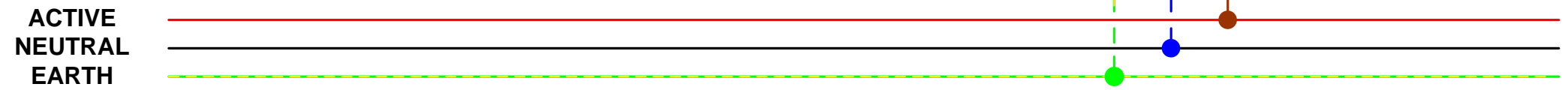
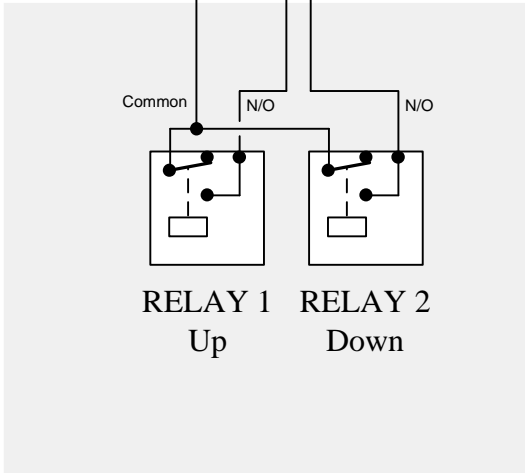

230 V 50Hz

5.0 WIND SENSOR SHROUD

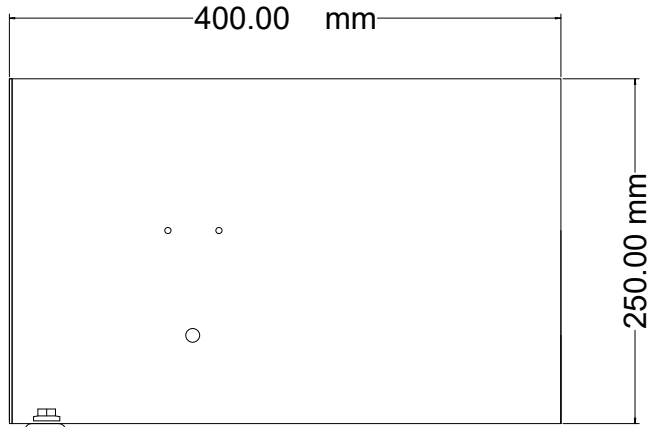

 CLIP LOCK ROOF SHEET CLAMPS

Shroud can be surface mounted or bolted to clip lock roof sheet when using roof clamps

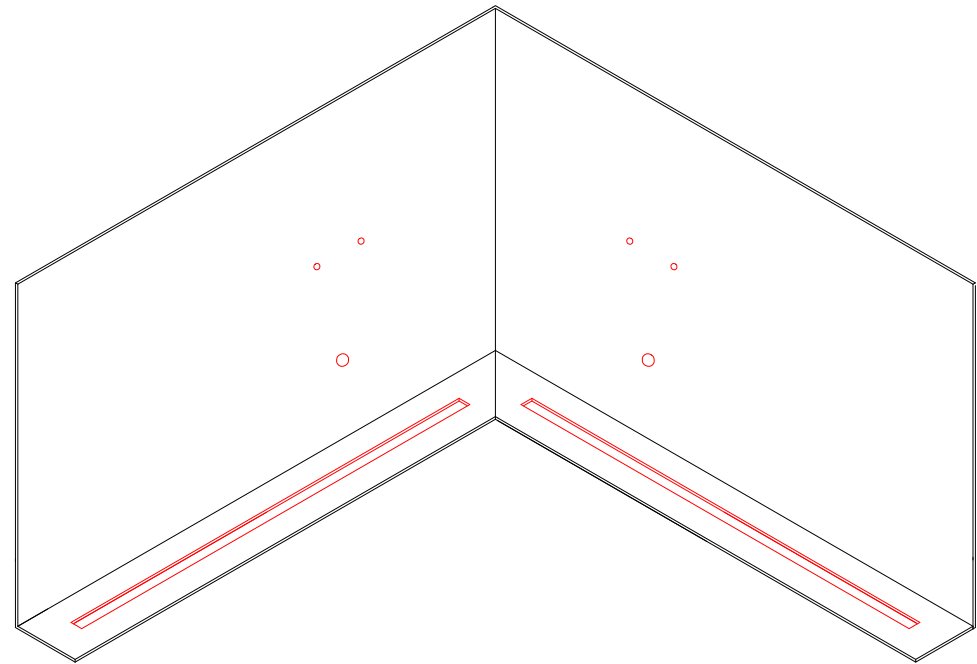
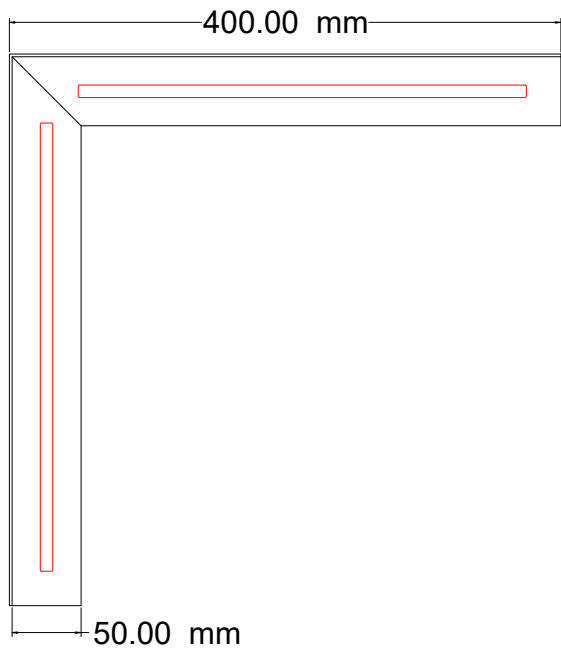

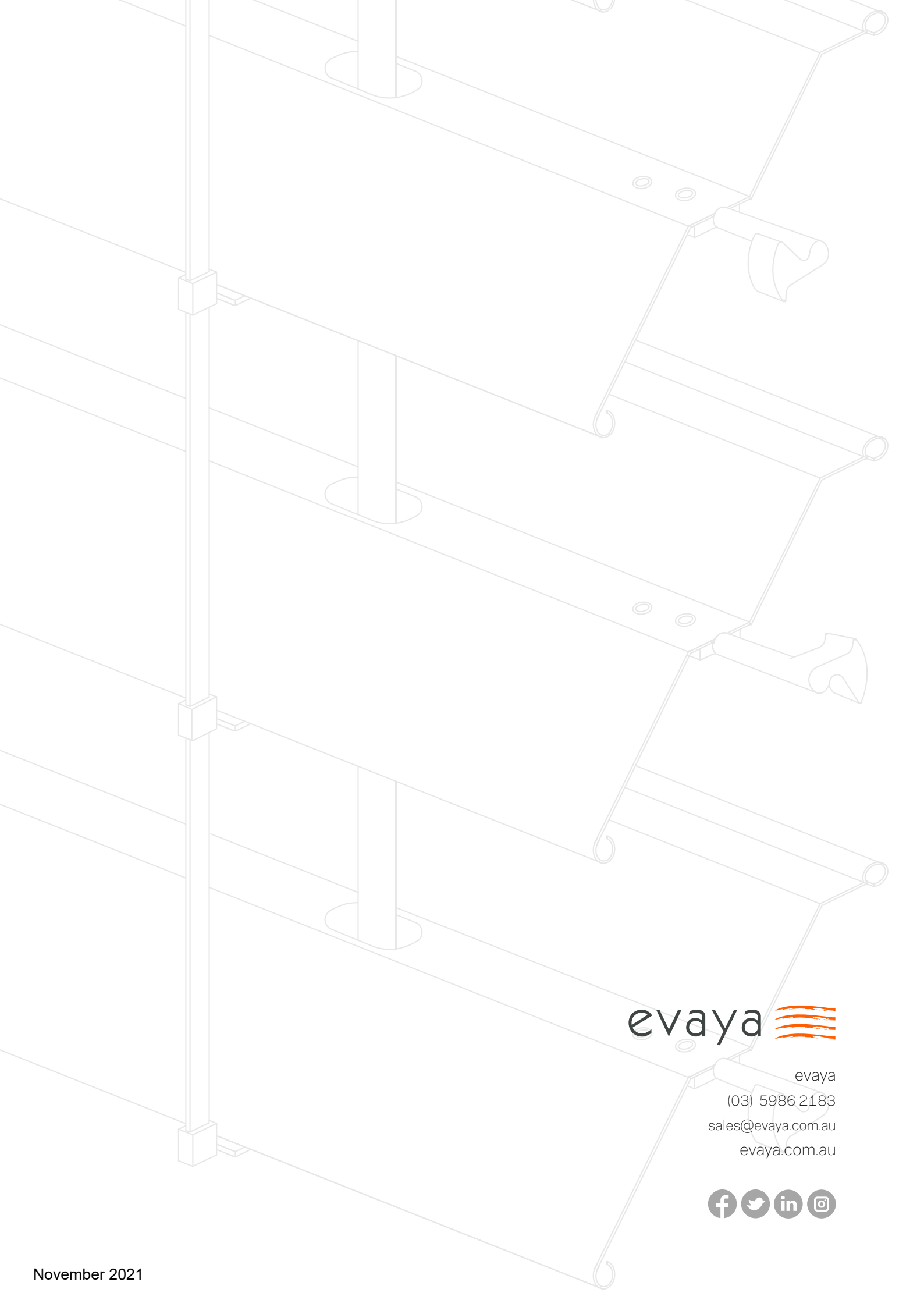

evaya 

evaya
(03) 5986 2183
sales@evaya.com.au
evaya.com.au

